

**Characteristics**

Pilot operated pressure relief valves series R5V have a similar design to the subplate mounted R4V series. The SAE flanges allow to mount the valves directly on the outlet flanges of pumps or inlet flanges of actuators to achieve a very compact design.

Valves with SAE flanges can also be bolted together to combine functions without the need of a manifold block.

**Features**

- Pilot operated with manual adjustment
- Body with 3-ports
  - 4 sizes (SAE 3/4", 1", 1 1/4", 1 1/2")
  - SAE61 and SAE62 flange
- 3 pressure stages
- 3 adjustment modes
  - Hand knob
  - Acorn nut with lead seal
  - Cylinder lock
- With optional vent function

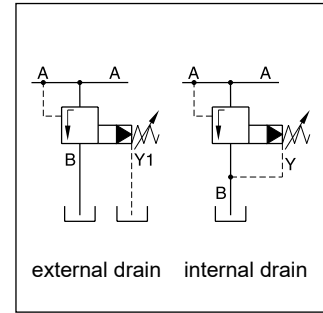

**R5V**

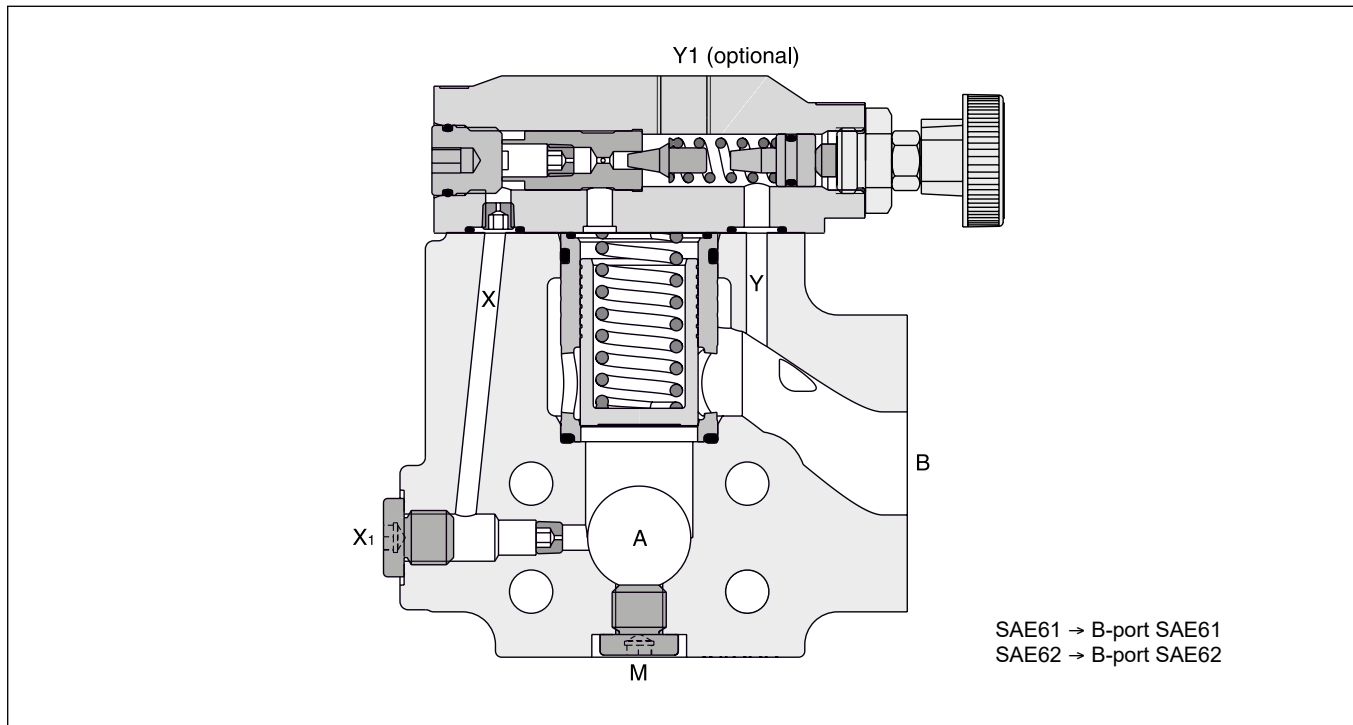

9

Ordering Code

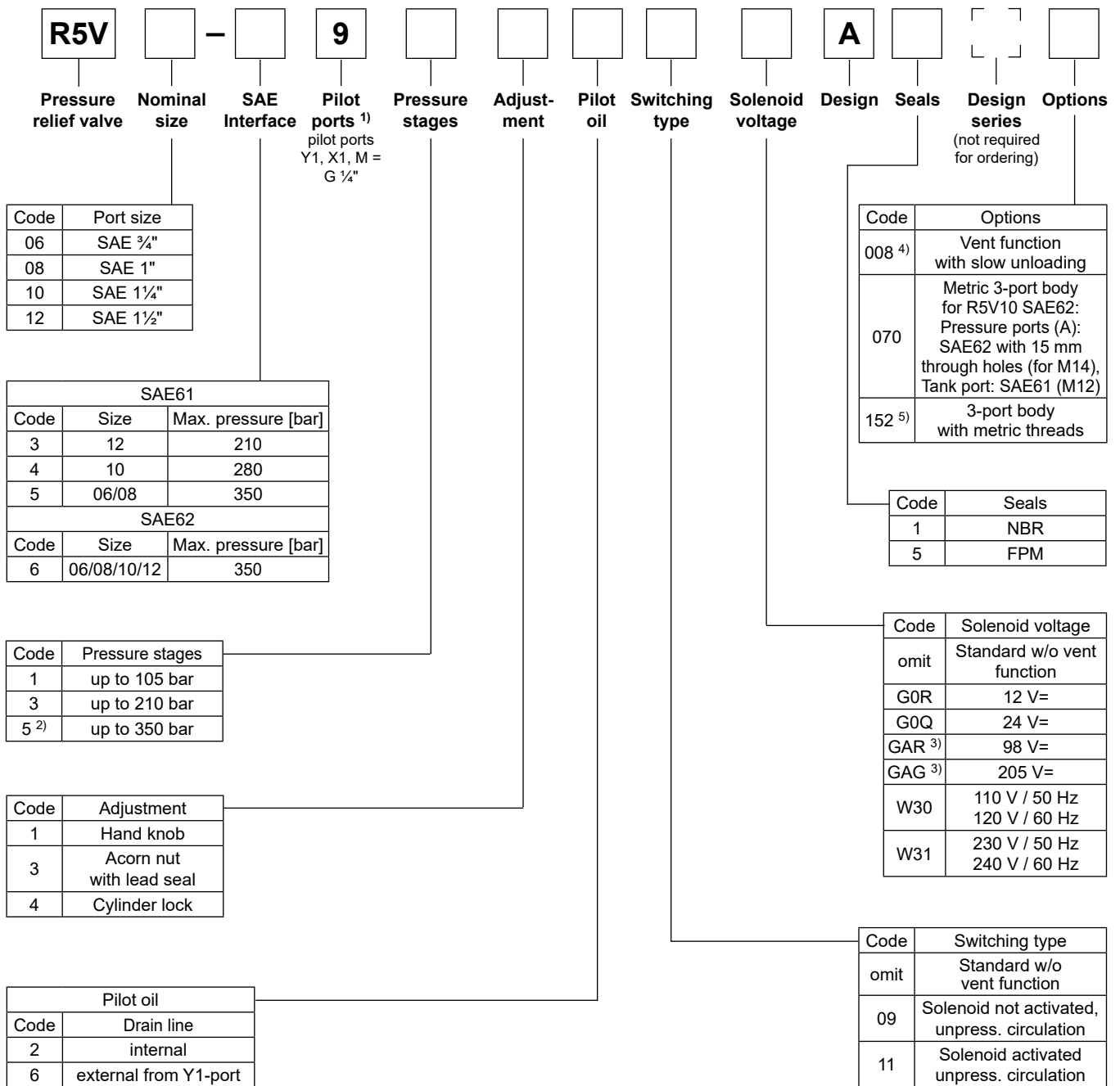

Further options on request

<sup>1)</sup> Y1 only available at external drain (pilot oil code 6).  
<sup>2)</sup> R5V10-495 up to 280 bar.  
<sup>3)</sup> To be used in combination with rectifier plugs at 120 VAC / 230 VAC power supply.  
<sup>4)</sup> Only for vent valve function code 09.  
<sup>5)</sup> R5V08 SAE62: Tank port SAE61 (M10).

Technical Data / Characteristic Curves

Technical data

General							
Size		<b>06 (3/4")</b>	<b>08 (1")</b>	<b>10 (1 1/4")</b>	<b>12 (1 1/2")</b>		
Mounting	Flanged according to SAE61 and SAE62						
Mounting position	unrestricted						
Ambient temperature	[°C]	-20...+60					
MTTF <sub>D</sub> value	[years]	75					
Weight	[kg]	3.6	4.6	5.2	8.0		
Hydraulic							
Max. operating pressure	[bar]						
SAE61 Ports A, B		350	350	280	210		
Port Y1		30	30	30	30		
SAE62 Ports A, B		350	350	350	350		
Port Y1		30	30	30	30		
Pressure stages	[bar]	105, 210, 350					
Nominal flow	[l/min]	90	300	600	600		
Fluid	Hydraulic oil according to DIN 51524						
Fluid temperature	[°C]	-20...+70 (NBR: -25...+70)					
Viscosity, permitted	[cSt] / [mm <sup>2</sup> /s]	20 ... 400					
Viscosity, recommended	[cSt] / [mm <sup>2</sup> /s]	30...80					
Filtration	ISO 4406 (1999); 18/16/13						
Electrical (solenoid)							
Duty ratio	100 % ED; CAUTION: coil temperature up to 150 °C possible						
Protection class	IP65 in accordance with EN 60529 (with correctly mounted plug-in connector)						
	Code	G0R	G0Q	GAR	GAG	W30	W31
Supply voltage	[V]	12 V =	24 V =	98 V =	205 V =	110 at 50 Hz	230 at 50 Hz
	[V]					120 at 60 Hz	240 at 60 Hz
Tolerance supply voltage	[%]	±10	±10	±10	±10	±5	±5
Current consumption	hold [A]	2.72	1.29	0.33	0.13	0.6 / 0.55	0.3 / 0.27
	in rush [A]	2.72	1.29	0.33	0.13	2.5 / 2.4	1.25 / 1.2
Power consumption	hold [W]	32.7	31	31.9	28.2	70/70 VA	70/70 VA
	in rush [W]	32.7	31	31.9	28.2	280/290 VA	280/290 VA
Solenoid connection	Connector as per EN175301-803, solenoid identification as per ISO 9461						
Wiring min.	[mm <sup>2</sup> ]	3 x 1.5 recommended					
Wiring length max.	[m]	50 recommended					

9

p/Q performance curve

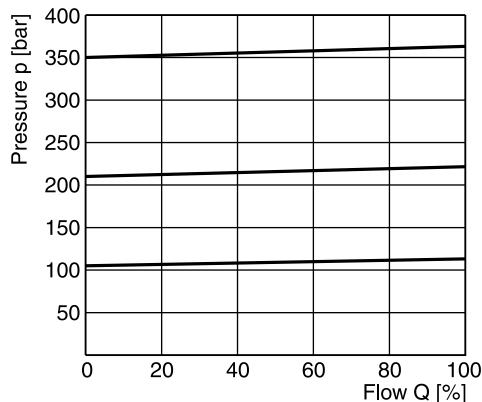

Minimum pressure curve

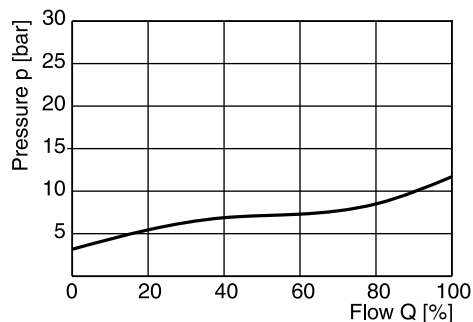

All characteristic curves measured with HLP46 at 50 °C.

The performance curves are measured with external drain.  
For internal drain the tank pressure has to be added to curve.

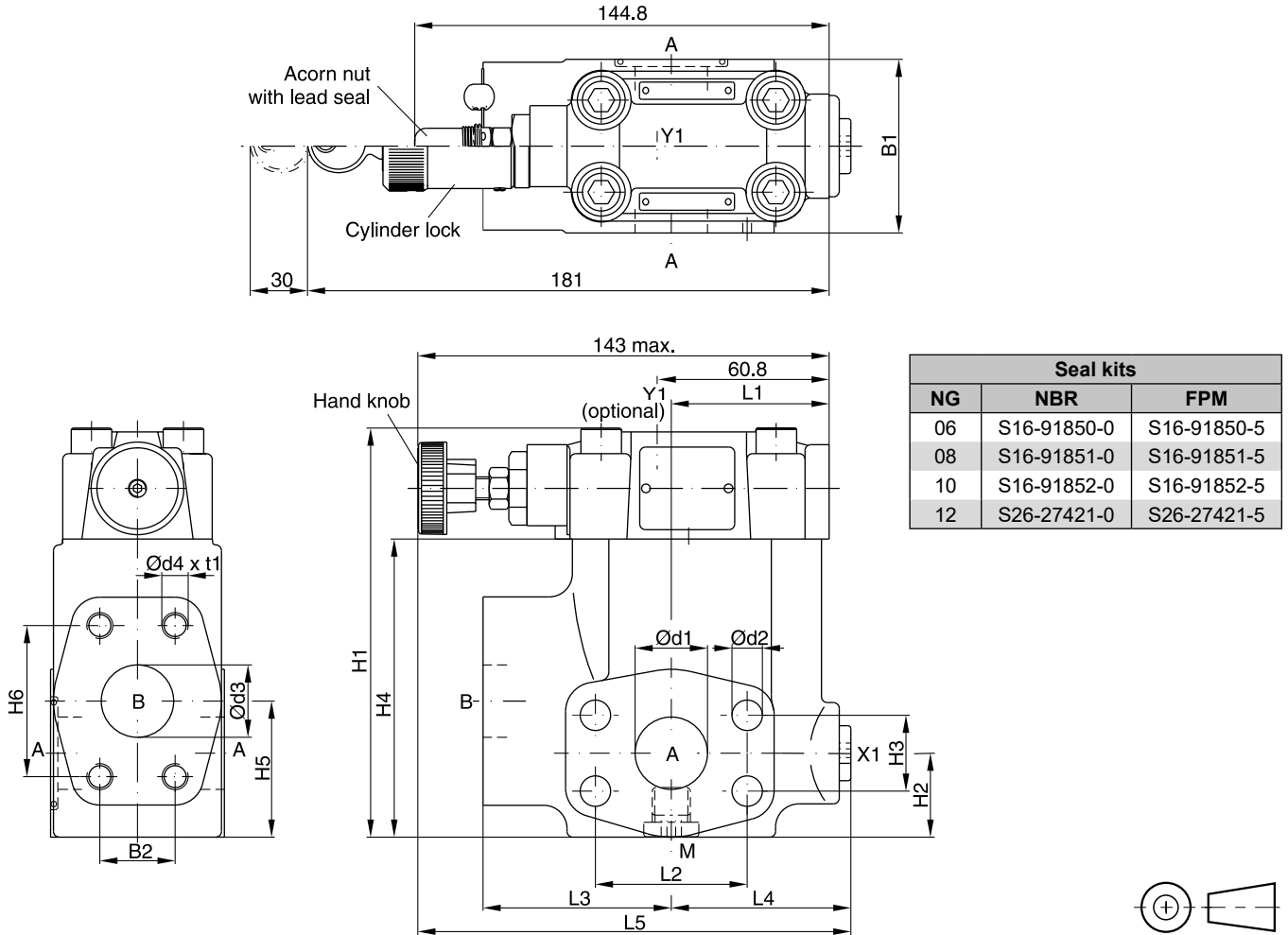

**SAE61**

NG	B1	B2	H1	H2	H3	H4	H5	H6	L1	L2	L3	L4	L5	d1	d2	d3	d4 (option 152)	t1
06	60	22.2	119	29.5	22.2	81	41	47.6	50.3	47.6	63	60	152	19	10.5	19	3/8"-16 UNC (M10)	20
08	60	26.2	141	30.5	26.2	103	47	52.4	55.8	52.4	65	62	149	25	10.5	25	3/8"-16 UNC (M10)	23
10	75	30.2	151	37.5	30.2	113	65	58.7	57.8	58.7	61	68	150.5	32	12.5	30	7/16"-14 UNC (M12)	22
12	80	35.7	178	72	35.7	140	73	69.8	37.3	69.8	92.5	59.2	171.2	38	13.5	38	1/2"-13 UNC (M12)	27

**SAE62**

NG	B1	B2	H1	H2	H3	H4	H5	H6	L1	L2	L3	L4	L5	d1	d2	d3	d4 (option 152)	t1
06	60	23.8	119	29.5	23.8	81	41	50.8	50.3	50.8	63	60	152	19	10.5	19	3/8"-16 UNC (M10)	20
08	60	27.8	141	30.5	27.8	103	47	57.2	55.8	57.2	65	62	149	25	12.5	25	7/16"-14 UNC (M10) <sup>1)</sup>	22
10	75	31.8	151	37.5	31.8	113	65	66.7	57.8	66.7	61	68	150.5	32	13.5	30	1/2"-13 UNC (M12)	24
12	80	36.5	178	72	36.5	140	73	79.4	37.3	79.4	92.5	59.2	171.2	38	17	38	5/8"-11 UNC (M16)	33

Port	Function	Port size			
		R5V06	R5V08	R5V10	R5V12
A (2)	Pressure	3/4" SAE61/62	1" SAE61/62	1 1/4" SAE61/62	1 1/2" SAE61/62
B	Tank	3/4" SAE61/62	1" SAE61/62	1 1/4" SAE61/62	1 1/2" SAE61/62
X1	External pilot port <sup>2)</sup>	G 1/4"	G 1/4"	G 1/4"	G 1/4"
Y1	External drain	G 1/4"	G 1/4"	G 1/4"	G 1/4"
M	Pressure gauge	G 1/4"	G 1/4"	G 1/4"	G 1/4"

<sup>1)</sup> T-port SAE61.  
<sup>2)</sup> Closed when supplied.

**Dimensions R5V with vent function**

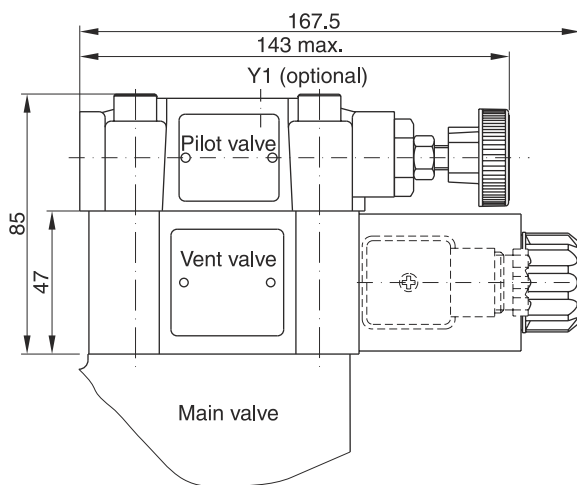
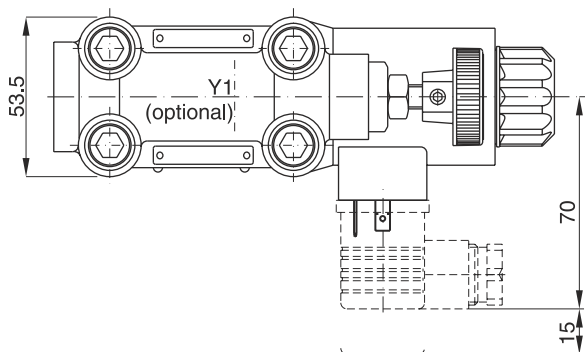

Seal kits	
NBR	FPM
<b>DC solenoid</b>	
S56-40609-0	S56-40609-5
<b>AC solenoid</b>	
S26-35237-0	S26-35237-5

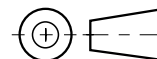

9

Code	Internal drain	External drain
11		
09		