

# Pressure reducing valve, direct operated

## Type DR 6 DP

**RE 26564**

Edition: 2019-01

Replaces: 05.11



H7743

- ▶ Size 6
- ▶ Component series 5X
- ▶ Maximum operating pressure 315 bar
- ▶ Maximum flow 60 l/min

### Features

- ▶ For subplate mounting
- ▶ Porting pattern according to ISO 4401-03-02-0-05 (with or without locating hole)
- ▶ 5 pressure ratings
- ▶ 4 adjustment types, optionally:
  - Rotary knob
  - Grub screw with hexagon and protective cap
  - Lockable rotary knob with scale
  - Rotary knob with scale
- ▶ Check valve, optional
- ▶ Corrosion-protected design

### Contents

Features	1
Ordering code	2
Symbols	3
Function, section	4
Technical data	5
Characteristic curves	6
Dimensions	7, 8
Further information	8

## Ordering code

01	02	03	04	05	06	07	08	09	10
DR 6 DP		-	5X	/		Y			*

01	Pressure reducing valve, direct operated, size 6	DR 6 DP
----	--	---------

### Adjustment type

02	Rotary knob	1
	Grub screw with hexagon and protective cap	2
	Lockable rotary knob with scale	3 <sup>1)</sup>
	Rotary knob with scale	7

03	Component series 50 ... 59 (50 ... 59: unchanged installation and connection dimensions)	5X
----	--	----

### Maximum secondary pressure

04	25 bar	25
	75 bar	75
	150 bar	150
	210 bar	210
	315 bar (Only with adjustment type "2" and without check valve)	315

05	Internal pilot oil supply, external pilot oil return	Y
----	--	---

06	With check valve	no code
	Without check valve	M

### Corrosion resistance

07	None	no code
	Improved corrosion protection (240 h salt spray test according to EN ISO 9227); (only version "1" and "2")	J3

### Seal material (observe compatibility of seals with hydraulic fluid used, see page 5)

08	NBR seals	no code
	FKM seals	V
	Observe compatibility of seals with hydraulic fluid used.	

09	Without locating hole	no code
	With locating hole	/60 <sup>2)</sup>
	With locating hole and locking pin ISO 8752-3x8-St	/62

10	Further details in the plain text	
----	-----------------------------------	--

<sup>1)</sup> H-key with the material no. **R900008158** is included in the scope of delivery.

<sup>2)</sup> Locking pin ISO 8752-3x8-St, material no. **R900005694** (separate order)

#### Notes:

- ▶ For valve types for use in potentially explosive areas, refer to data sheet 07011.
- ▶ Preferred types and standard units are contained in the EPS (standard price list).

### Symbols

Without check valve "M"

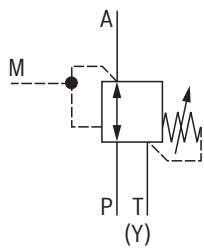

With check valve "no code"

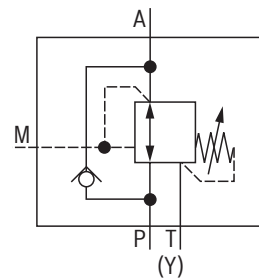

## Function, section

The valve type DR 6 DP is a direct operated pressure reducing valve in 3-way version, i.e. with pressure limitation of the secondary circuit.

It is used to reduce a system pressure. The secondary pressure is set using the adjustment type (4).

The valve is open in initial position. Hydraulic fluid can flow from channel P to channel A without restrictions. The pressure in channel A is simultaneously applied via the control line (6) at the piston area opposite the compression spring (3). If the pressure in channel A exceeds the value set at the compression spring (3), the control spool (2) moves into control position and keeps the set pressure in channel A at a constant level.

Signal and pilot oil are supplied internally via the control line (6) from channel A.

If the pressure in channel A increases further due to an external force effect at the actuator, it pushes the control spool (2) even further against the compression spring (3). In this way, channel A is connected to the channel T(Y) via the control edge (8) at the control spool (2). Hydraulic fluid is discharged into the tank to an extent that the pressure can only slightly increase.

The leakage oil discharge from the spring chamber (7) is always effected externally via the channel T(Y).

For the free flow back from channel A to P, a check valve (5) can optionally be installed.

A pressure gauge connection (1) allows for the control of the secondary pressure.

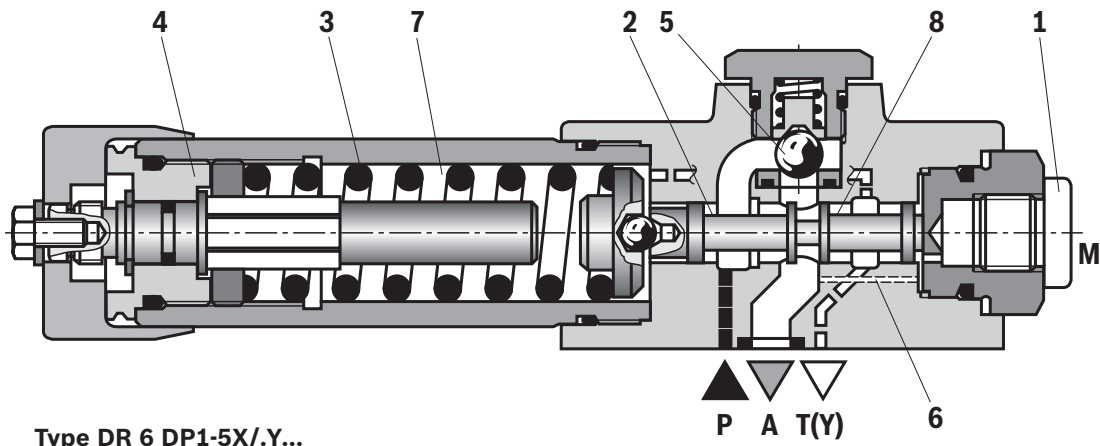

## Technical data

(For applications outside the stated values, please ask us!)

general		
Weight	kg	ca. 1.2
Installation position		any
Ambient temperature range	°C	-30 ... +80 (NBR seals) -20 ... +80 (FKM seals)
MTTF <sub>D</sub> values according to EN ISO 13849	Years	150 ... 1200 (for more information see data sheet 08012)

hydraulic			
Maximum operating pressure	▶ Port P	bar	315
Maximum secondary pressure	▶ Port A	bar	25; 75; 150; 210; 315
Maximum counter pressure	▶ Port T(Y)	bar	160
Maximum flow		l/min	60
Hydraulic fluid			see table below
Hydraulic fluid temperature range		°C	-30 ... +80 (NBR seals) -20 ... +80 (FKM seals)
Viscosity range		mm <sup>2</sup> /s	10 ... 800
Maximum admissible degree of contamination of the hydraulic fluid, cleanliness class according to ISO 4406 (c)			class 20/18/15 <sup>1)</sup>

Hydraulic fluid	Classification	Suitable sealing materials	Standards	Data sheet
Mineral oils	HL, HLP, HLPD, HVLP, HVLDP	NBR, FKM	DIN 51524	90220
Bio-degradable	▶ Insoluble in water	HETG	ISO 15380	90221
		HEES		
	▶ Soluble in water	HEPG	ISO 15380	
Flame-resistant	▶ Water-free	HFDU (glycol base)	ISO 12922	90222
		HFDU (ester base)		
		HFDR		
	▶ Containing water	HFC (Fuchs: Hydrotherm 46M, Fuchs Renosafe 500; Petrofer: Ultra Safe 620; Houghton: Safe 620; Union: Carbide HP5046)	ISO 12922	90223



### Important information on hydraulic fluids:

- ▶ For further information and data on the use of other hydraulic fluids, please refer to the data sheets above or contact us.
- ▶ There may be limitations regarding the technical valve data (temperature, pressure range, life cycle, maintenance intervals, etc.).
- ▶ The ignition temperature of the hydraulic fluid used must be 50 K higher than the maximum surface temperature.
- ▶ **Bio-degradable and flame-resistant – containing water:** If components with galvanic zinc coating (e.g. version "J3" or "J5") or parts containing zinc are used, small amounts of dissolved zinc may get into the hydraulic system and cause accelerated aging of the hydraulic fluid. Zinc soap may form as a chemical reaction product, which may clog filters, nozzles and solenoid valves - particularly in connection with local heat input.

### ▶ Flame-resistant – containing water:

Due to increased cavitation tendency with HFC hydraulic fluids, the life cycle of the component may be reduced by up to 30% as compared to the use with mineral oil HLP. In order to reduce the cavitation effect, it is recommended - if possible specific to the installation - to back up the return flow pressure in ports T to approx. 20% of the pressure differential at the component.

<sup>1)</sup> The cleanliness classes specified for the components must be adhered to in hydraulic systems. Effective filtration prevents faults and simultaneously increases the life cycle of the components.

For the selection of filters, see [www.boschrexroth.com/filter](http://www.boschrexroth.com/filter).

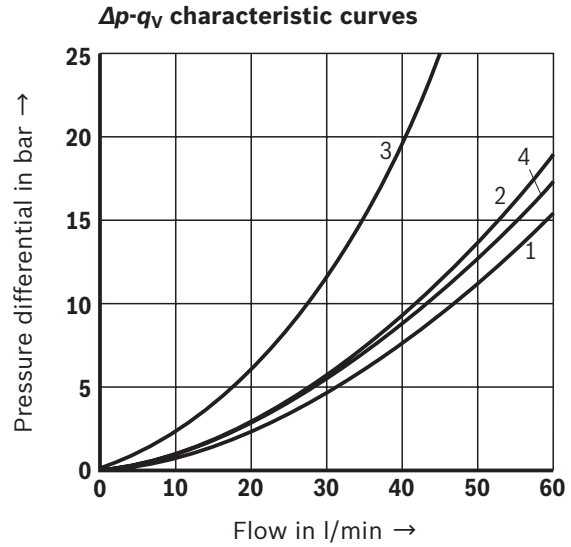
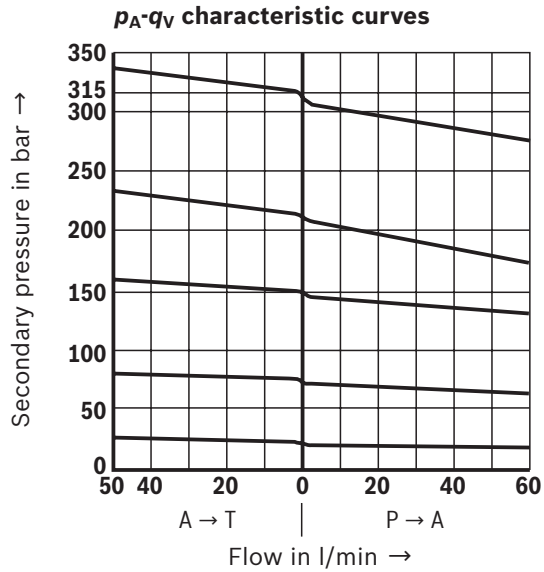
**Characteristic curves**(measured with HLP46,  $\vartheta_{oil} = 40 \pm 5^\circ\text{C}$ )

- 1 P → A (minimum pressure differential)
- 2 A → T(Y) (minimum pressure differential)
- 3  $\Delta p$  only via check valve
- 4  $\Delta p$  via check valve and fully opened control cross-section

**Notes:**

- ▶ The curve development is maintained if the pressure is set lower according to the pressure rating.
- ▶ The characteristic curves apply to the pressure at the valve output  $p_T = 0$  bar across the entire flow range.

## Dimensions (dimensions in mm)

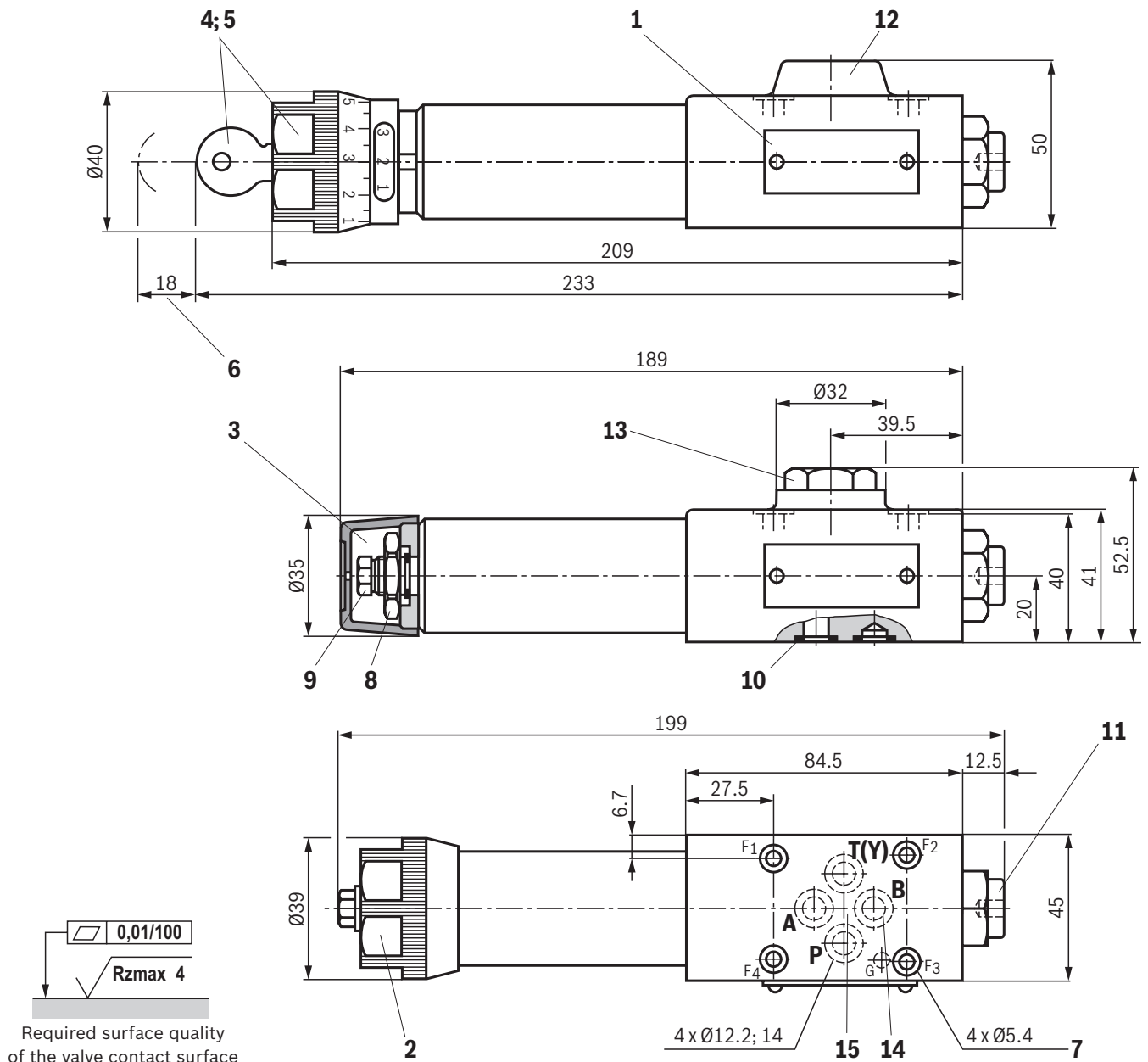

- 1 Name plate
- 2 Adjustment type "1"
- 3 Adjustment type "2"
- 4 Adjustment type "3"
- 5 Adjustment type "7"
- 6 Space required to remove the key
- 7 Valve mounting bores
- 8 Lock nut SW24
- 9 Hexagon, wrench size 10
- 10 Identical seal rings for ports A, B, P, T(Y)
- 11 Pressure gauge connection G1/4; 12 deep; internal hexagon SW6
- 12 Without check valve
- 13 With check valve
- 14 Port B without function
- 15 Porting pattern according to ISO 4401-03-02-0-05 (with or without locating hole); (**with** locating hole for locking pin ISO 8752-3x8-St; version "/60")

### Notice:

The dimensions are nominal dimensions which are subject to tolerances.

**Valve mounting screws and subplates, see page 8.**

## Dimensions

### Valve mounting screws (separate order)

Size	Quantity	Hexagon socket head cap screws	Material number
6	4	<b>ISO 4762 - M5 x 50 - 10.9-CM-Fe-ZnNi-5-Cn-T0-H-B</b> friction coefficient $\mu_{\text{total}} = 0.09 \dots 0.14$ ; tightening torque $M_A = 7 \text{ Nm} \pm 10\%$	<b>R913043758</b>
	or		
	4	<b>UNC 10-24 UNC x 2" ASTM-A574</b> Friction coefficient $\mu_{\text{total}} = 0.19 \text{ to } 0.24$ ; tightening torque $M_A = 11 \text{ Nm} [8.2 \text{ ft-lbs}] \pm 15\%$ Friction coefficient $\mu_{\text{total}} = 0.12 \text{ to } 0.17$ ; tightening torque $M_A = 8 \text{ Nm} [5.9 \text{ ft-lbs}] \pm 10\%$	<b>R978800693</b>

**Subplates** (separate order) with porting pattern according to ISO 4401-03-02-0-05 see data sheet 45100.

## Further information

- |   |  |
|---|--|
| ▶ Hydraulic valves for industrial applications                                  | Operating instructions 07600-B   |
| ▶ Subplates   | Data sheet 45100   |
| ▶ Hydraulic fluids on mineral oil basis   | Data sheet 90220   |
| ▶ Environmentally compatible hydraulic fluids                                   | Data sheet 90221   |
| ▶ Flame-resistant, water-free hydraulic fluids                                  | Data sheet 90222   |
| ▶ Flame-resistant hydraulic fluids - containing water (HFAE, HFAS, HFB, HFC)    | Data sheet 90223   |
| ▶ Reliability characteristics according to EN ISO 13849                         | Data sheet 08012   |
| ▶ Use of non-electrical hydraulic components in an explosive environment (ATEX) | Data sheet 07011   |
| ▶ Selection of filters  | <a href="http://www.boschrexroth.com/filter">www.boschrexroth.com/filter</a> |
| ▶ Information on available spare parts  | <a href="http://www.boschrexroth.com/spc">www.boschrexroth.com/spc</a>       |

Bosch Rexroth AG  
Industrial Hydraulics  
Zum Eisengießer 1  
97816 Lohr am Main, Germany  
Phone +49 (0) 93 52/ 40 30 20  
[my.support@boschrexroth.de](mailto:my.support@boschrexroth.de)  
[www.boschrexroth.de](http://www.boschrexroth.de)

© All rights reserved to Bosch Rexroth AG, also regarding any disposal, exploitation, reproduction, editing, distribution, as well as in the event of applications for industrial property rights.  
The data specified above only serve to describe the product. No statements concerning a certain condition or suitability for a certain application can be derived from our information. The information given does not release the user from the obligation of own judgment and verification.  
It must be remembered that our products are subject to a natural process of wear and aging.