



DESCRIPTION

- One stage
- 240 volts
- 5.7"/145 mm diameter
- Double Ball Bearings
- Single speed
- Thru-flow discharge
- Aluminum fan end bracket
- Aluminum commutator bracket

DESIGN APPLICATION

- Equipment operating in environments not requiring separation of working air from motor ventilating air
- Designed to handle clean, dry, filtered air only

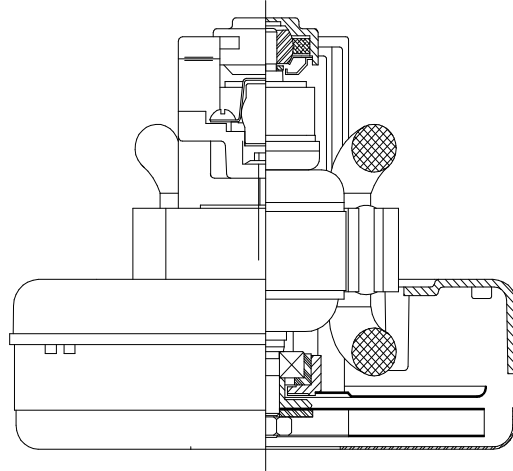

SPECIAL FEATURES

- Suitable for 240 volt AC operation, 50/60 Hz
- UL recognized, category PRGY2 (E47185)
- Provision for grounding
- Skeleton-frame design
- The Lamb Electric vacuum motor line offers a wide range of performance levels to meet design needs

TYPICAL MOTOR PERFORMANCE.*

(At 240 volts, 60Hz, test data is corrected to standard conditions of 29.92 Hg, 68° F.)

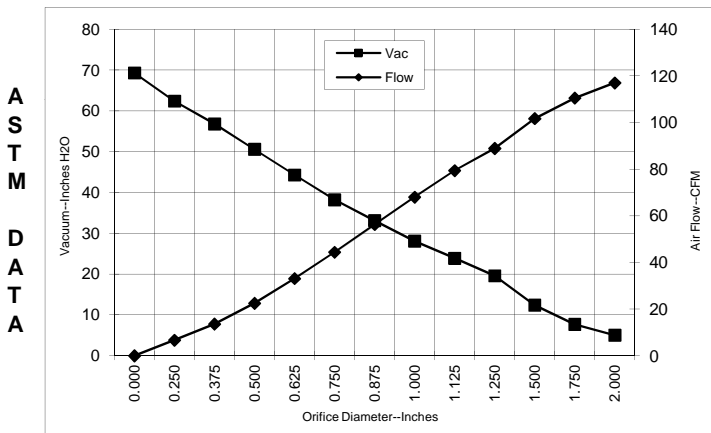

Orifice (Inches)	Amps	Watts (In)	RPM	Vac (In.H2O)	Flow (CFM)	Air Watts
2.000	4.2	963	22042	5.1	117.0	69
1.750	4.2	975	21936	7.7	110.5	101
1.500	4.2	988	21639	12.4	101.7	149
1.250	4.2	985	21639	19.6	88.9	205
1.125	4.0	957	21946	23.9	79.4	223
1.000	3.9	937	22275	28.1	68.0	225
0.875	3.7	900	22794	33.1	56.3	219
0.750	3.6	857	23494	38.2	44.4	200
0.625	3.4	801	24394	44.3	33.1	172
0.500	3.1	749	25465	50.6	22.5	134
0.375	2.8	695	26895	56.8	13.6	91
0.250	2.6	646	28082	62.4	6.7	49
0.000	2.5	614	28824	69.3	0.0	0

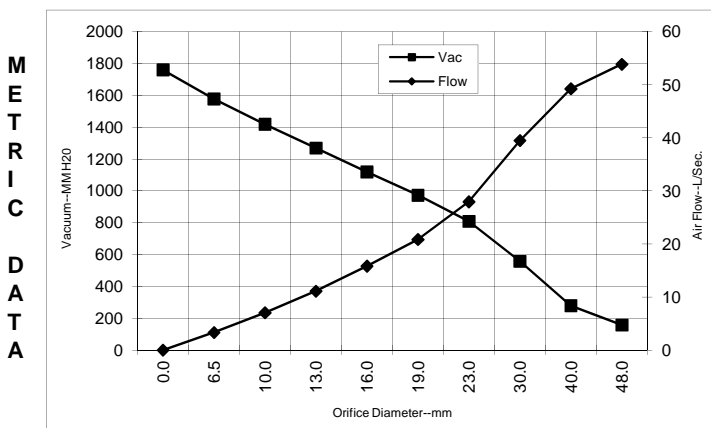

Orifice (mm)	Amps	Watts (In)	RPM	Vac (mm H2O)	Flow (L/Sec)	Air Watts
48.0	4.2	968	21995	158	53.9	83
40.0	4.2	984	21728	279	49.2	135
30.0	4.1	970	21808	558	39.5	215
23.0	3.8	909	22664	809	28.0	221
19.0	3.6	856	23512	973	20.9	199
16.0	3.4	803	24358	1119	15.8	173
13.0	3.1	754	25358	1269	11.1	138
10.0	2.9	703	26681	1419	7.0	97
6.5	2.6	648	28023	1578	3.3	51
0.0	2.5	614	28824	1760	0.0	0

Note: Metric performance data is calculated from the ASTM data above.

* Data represents performance of a typical motor sampled from a large production quantity. Individual motor data may vary due to normal manufacturing variations.

Test Specs:	240 volts	Minimum Sealed Vacuum:	63.0"	ORIFICE:	7/8 "	Minimum Vacuum:	29.0"	Maximum Watts:	1010
--------------------	-----------	-------------------------------	-------	-----------------	-------	------------------------	-------	-----------------------	------

DIMENSIONS

NOTES:

- LEADS: 18GA STRANDED, LEADS CAN BE ANY COLOR EXCEPT GREEN OR GREEN WITH YELLOW STRIPE.
- GROUNDING OR EARTHING PROVISIONS: USE HOLES AS INDICATED FOR GROUNDING OR EARTHING. REFER TO APPROPRIATE LISTING OR REGULATORY AGENCY FOR PROPER METHOD OF GROUNDING OR EARTHING.

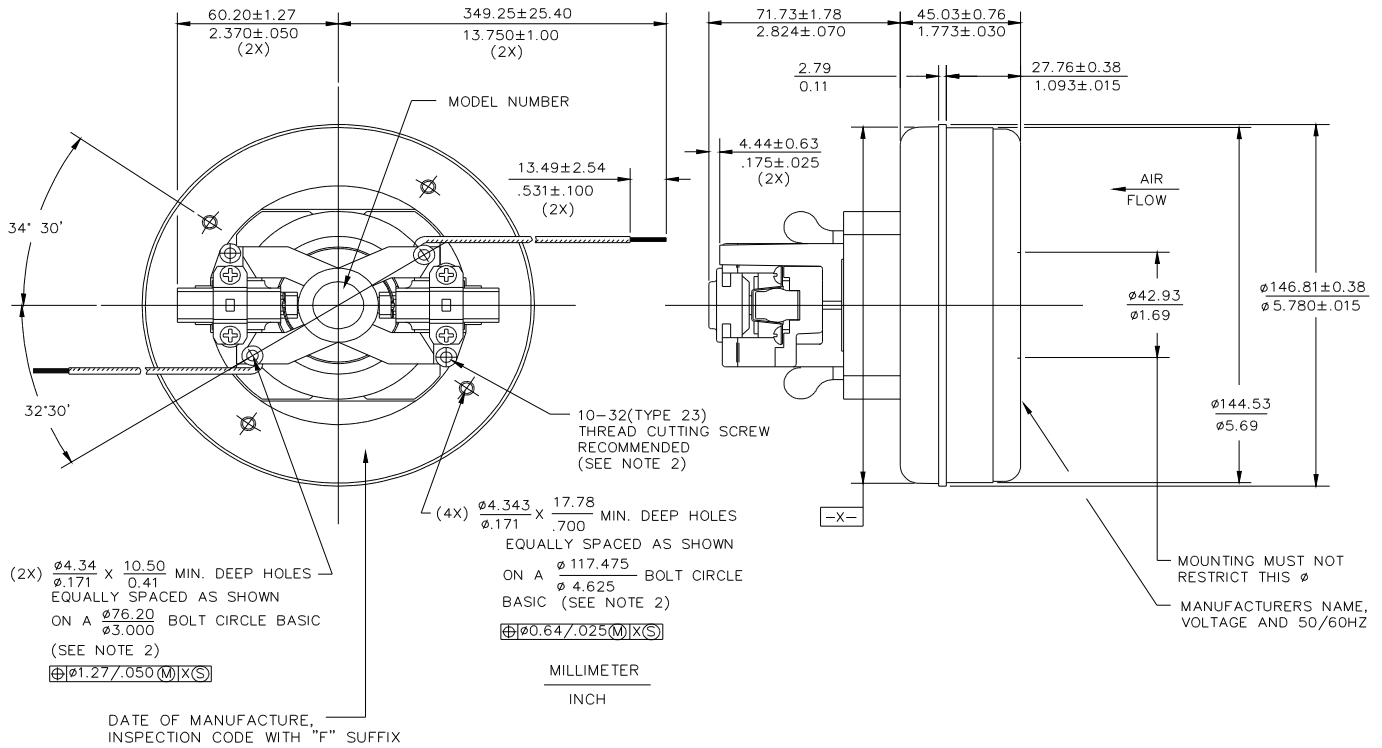

IMPORTANT NOTE: Pictorial and dimensional data are subject to change without notice. Contact factory for current revision levels.

WARNING - AMETEK Lamb Electric thru-flow vacuum motors must never be used in applications in which wet or moist conditions are involved, where dry chemicals or other volatile materials are present, or where airflow may be restricted or blocked. Such motors are designed to permit the vacuumed air to pass over the electrical winding to cool it. Thus any foam, liquid (including water), dry chemical, or other foreign substance coming in contact with electrical conductors could cause combustion (depending on volatility) or electrical shock. Failure to observe these precautions could result in property damage and severe personal injury, including death in extreme cases. All applications incorporating Lamb Electric motors should be submitted to Underwriters Laboratories Inc. or other appropriate organizations or agencies for testing specifically related to the safety of your equipment.

AMETEK/Floorcare & Specialty Motors
www.ametekfsm.com